

# DESIGN GUIDE

VERSION 7.0 AUGUST 2024

**STOPDIGGING!**  
THE GROUND SCREW FOR SOLID FOUNDATIONS

**CodeMark**   
CMNZ70132

## CONTENTS

<b>How this document is organised.....</b>	<b>2</b>
Purpose.....	2
Description.....	2
<b>Part 1 STOPDIGGING! Ground screw foundation system – Pre-engineered solution.....</b>	<b>3</b>
<b>Introduction .....</b>	<b>3</b>
Scope.....	3
Skills required.....	3
Important documents.....	3
Worked examples for Part 1.....	3
<b>Design Process .....</b>	<b>4</b>
Step 1 Confirm building scope.....	4
Step 2 Confirm ground / soil suitability.....	4
Step 3 Determine Design Loads.....	4
Step 5 Complete building consent documentation.....	7
<b>Part 2 For building projects requiring specific engineering foundation design.....</b>	<b>8</b>
<b>Introduction .....</b>	<b>8</b>
Scope.....	8
Skills Required.....	8
Important Documents.....	8
Worked examples for Part 2.....	8
<b>Design Process .....</b>	<b>9</b>
Step 1 Confirm building scope.....	9
Step 2 Confirm ground conditions.....	9
Step 3 Determine Design Loads & Ground Screw Position.....	9
Step 5 Specify ground screws, connections & fixings.....	12
Step 6 Complete building consent documentation.....	15
<b>Appendix 1 – Soil suitability.....</b>	<b>16</b>
<b>Appendix 2 – Design and Test Loads.....</b>	<b>17</b>
<b>Appendix 3 – Foundation System Worked Examples.....</b>	<b>18</b>
<b>Appendix 4 – Example engineering calculations.....</b>	<b>21</b>



**HOW THIS DOCUMENT IS ORGANISED**

**PURPOSE**

This guide provides:

- a. the information to design and specify a STOPDIGGING! ground screw foundation system using the pre-engineered solution (Part 1); and
- b. the advice necessary to engage an engineer or, in the case of an engineer, the methodology required to design and specify a STOPDIGGING! ground screw foundation system (Part 2).

**DESCRIPTION**

STOPDIGGING! ground screws are circular hollow sections with a continuously welded helix manufactured from steel that complies with ISO 630 FE360A–High Tensile Steel for Structural Purposes. They are coated with a hot-dipped galvanised coating that achieves an average of 125 µm zinc cover. The STOPDIGGING! ground screws are classified as category HDG900 (900 g/m<sup>2</sup>).

They are capable of resisting vertical (tensile and compression) and lateral forces. Therefore, they can be specified as a proprietary foundation system, an alternative to traditional foundation piles and strip footings as defined in NZS 3604:2011 or a foundation subject to specific engineering design (SED).

STOPDIGGING! ground screws are mechanically installed into soil to a depth at which the required resistance is achieved.

The specification of STOPDIGGING! ground screws is only dependent on identifying pile design loads for either compressive or tensile loads and lateral loads. Load bearing verification is provided by on-site static pile testing.

STOPDIGGING! ground screws are supplied in various screw diameters with extensions, adapters, and connection brackets. The actual diameter and length of ground screws are established at the time of installation and based on the compressive and lateral loads achieved by on-site static pile testing.

GROUND SCREW DIAMETER (mm)	
SGC	SGU
76	67
89	
114	

The SGC range of screws and extensions is used for all structures with walls and roofs. The SGU range of screws are used for decking and boardwalk structures with a FFL less than 1m above ground level.

The screws can be installed without ground disturbance or damage and produce zero waste. Concrete is not required.

STOPDIGGING! ground screws are reusable and recyclable.

## **PART 1 STOPDIGGING! GROUND SCREW FOUNDATION SYSTEM – PRE-ENGINEERED SOLUTION**

### **INTRODUCTION**

#### **SCOPE**

Part 1 applies to projects where the pre-engineered STOPDIGGING! ground screw foundation system may be used. This part is referred to as 1(a) in the [CodeMark Certificate of Conformity](#). All the following conditions must be met if a project is to rely on the pre-engineered solution.

➤ Ground:

- where the soil type is listed as acceptable in [Table 1](#) of this guide, and
- liquefaction does not need to be considered in the foundation design, and
- lateral ground spread does not need to be considered in the foundation design, and
- where the foundations are situated on ground with adequate bearing capacity as established by static pile testing.

➤ Suspended subfloor:

- designed to:
  - i. the scope of NZS3604:2011 section 1.1.2 (b to o); or
  - ii. NASH Standard Part 2: May 2019 section 1.1.3; or
  - iii. where timber joists in a subfloor designed to 1(a)(i) or 1(a)(ii) are replaced with SteelHaus steel joists designed in accordance with Section 2 – Floor Framing of the SteelHaus Steel Framing Construction Manual V8 01.11.2023; or
  - iv. for existing subfloors, where the subfloor bracing complies with section 5.5, NZS3604:2011, and where

➤ Foundation:

- the maximum floor live load does not exceed 3kPa, and
- the head of the ground screw < 900 mm above ground level, and
- diagonal bracing is not required, and
- the spacing between joists and bearers is within the scope of [Table 3](#) or [Table 4](#), Appendix 2 of this guide.

For projects that fall outside this scope, refer to [Part 2](#) of this guide.

#### **SKILLS REQUIRED**

Part 1 is intended for use by licensed building practitioners (LBP), or deemed LBP, licensed to the applicable class.

Where consent is not required, then this part of the guide is also intended for use by a person who understands the principles of subfloor and foundation design.

#### **IMPORTANT DOCUMENTS**

When using Part 1 of this guide, the following documents will be required when lodging a building consent application:

- [CodeMark Certificate of Conformity](#) (where building consent applies).
- STOPDIGGING! Installation Guide.
- STOPDIGGING! Design Declaration signed by the designer who specified the foundation.
- Subfloor and foundation plan and specification.

Refer to [www.stopdigging.co.nz/screws-in-various-lengths/#docs](http://www.stopdigging.co.nz/screws-in-various-lengths/#docs) for current versions of STOPDIGGING! documents

#### **WORKED**

Refer to [Appendix 3](#) for worked examples.

#### **EXAMPLES FOR PART 1**

- Example 1: Level site with cantilevered piles - bracing units evenly distributed.
- Example 2: Level site with bracing units unevenly distributed.
- Example 3: Sloping ground with cantilevered piles.

## DESIGN PROCESS



### STEP 1

#### Confirm building scope

Confirm that the subfloor is designed with joist and bearer spans within the scope of the tables in 3 or 4, [Appendix 2](#) and that design floor loads do not exceed 3 kPa.



### STEP 2

#### Confirm ground / soil suitability

##### Confirm ground / soil suitability

[Table 2](#), [Appendix 1](#) provides a soil suitability matrix.

Confirm that the site-specific soil type is listed as suitable.

Where the soil is not covered in [Table 2](#), site soil testing and a geotechnical report will be required as part of the design process.

##### Confirm ground stability

Refer to council files and the applicable GIS to determine if liquefaction or other ground stability must be factored in when designing the foundation system.

Where a geotechnical report is required, the design of the foundation system must be carried out by a CPEng engineer, unless all conditions of 1 (a) of the CodeMark Certificate of Conformity can be met.



### STEP 3

#### Determine Design Loads

Provide a subfloor plan showing bearer size and position, joist size and position, and pile spacing. Ensure bearer and joist span are applicable dimensions in [tables 3 or 4](#) in [Appendix 2](#).

The STOPDIGGING! ground screw foundation system must be specified with reference to the ULS design loads assigned to each ground screw.

When used in conjunction with a subfloor, the ground screws can act as a cantilever "free head" pile whether bracing units are evenly or unevenly distributed.

##### Specify lateral design loads:

Lateral design loads are determined by dividing total subfloor bracing units by the total quantity of piles. This evenly distributes subfloor bracing throughout all piles.

The larger number of total subfloor bracing units of either 'along' or 'across' are divided by the number of piles to determine individual pile BU requirements,

Conversion to kN is in the ratio: 20 bracing units = 1 kN

### Specify compression or tension loads

Use the applicable table from [Appendix 2](#) to select the applicable design and test loads.

Appendix 2 provides tables that prescribe individual pile design and test loads for each of the subfloor designs that fall within the pre-engineered solution.

#### Note: On-site testing

The static pile test that must be undertaken prior to the installation of the foundation system must demonstrate that capacity is achieved to 100 % of the specified test load (compressive or tension and lateral).

The following scenarios are provided to describe possible options to meet the consented design test loads.

#### Scenario 1

A ground screw of a suitable size is tested for bearing capacity. If the required design load is not achieved, a larger diameter or longer length ground screw is tested until the required test loads are achieved. The installation of the foundation system can continue with the suitable size ground screw. Ground screw size and quantity installed is recorded in the Installation Declaration.

#### Scenario 2

Even with a larger ground screw, the test loads cannot be met. Additional STOPDIGGING! ground screws will be required, mirroring a smaller bearer or joist span. A minor variation will be required.

#### Scenario 3

Lateral test loads are not met. Diagonal bracing will be required. See [Part 2](#).

- a. A steel pipe bracing unit with or without a ground screw extension is installed. An amendment to the building consent will be required with the documentation prepared by a CPEng engineer.
- b. A timber senton post is installed to the top of the ground screw, and a timber diagonal bracing is then to be installed to the senton posts in accordance with NZS 3604:2011 Section 6.8. An amendment to the building consent will be required and can be prepared by the designer.



## STEP 4

### Specify ground screw to bearer connection

#### Select ground screw.

Specify SGC or SGU ground screws. Size (diameter and length) are confirmed at the time of static pile testing. However, the following should be specified:

- > SGU Screws are required for decks where the fall height is < 1 m.
- > SGC Screws are required for all other uses.

Specify SGL pile to bearer connection bracket for use with SGC ground screw.

The STOPDIGGING! SGL bracket is fixed to the head of the ground screw through a slotted hole using an M20 threaded bolt in the centre of the screw.

The bracket may be positioned in one of three orientations on the head of the screw depending on the position of the bearer relative to the head of the screw.

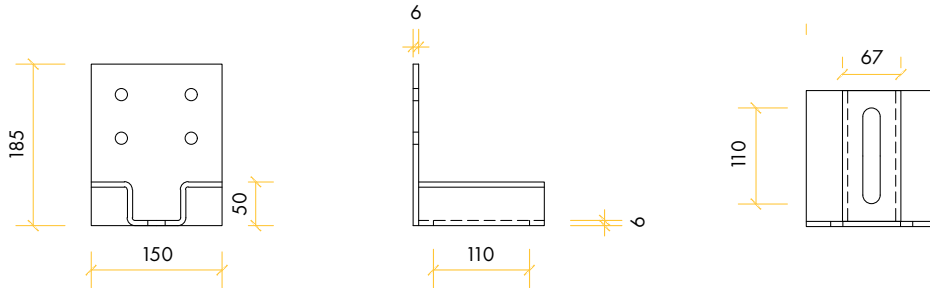

▲ FIGURE 1. BRACKET SGL145

Where fixing the bearer to the bracket, there are two fixing options that will achieve a 6 kN fixing:

- 1 x M12 bolt through bearer c/w 50 x 50 x 6 mm square washer or
- 2 x M12 coach screws (75 mm long)
- Washer required on timber side only
- Where fixed to a 150 x 150 x 4 RHS steel bearer use 5 x 14g tek screws. (Note, the existing M12 holes are not to be used when fixing with tek screws).

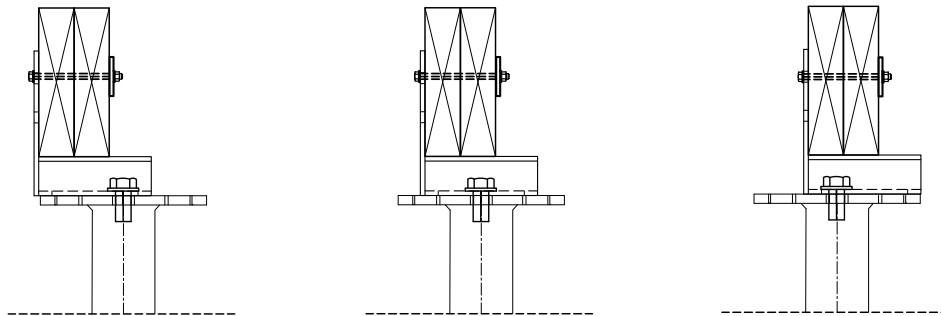

▲ FIGURE 2. POSITION OF GROUND SCREW

Refer to [Part 2](#) for details of ground screw to ground screw extension and diagonal bracing unit.



**STEP 5**  
**Complete building consent documentation**

To ensure consenting is streamlined, check that the following is provided.

- A single plan page showing foundation design and clearly detailing,
  - the position of the ground screws
  - the type of ground screw, but not the dimension or length
  - the brackets
  - connection details
  - fixing details
  - lateral design and test loads
  - compressive or tension design and test loads.
- A current copy of the STOPDIGGING! Ground Screw Foundation System CodeMark.
- A signed STOPDIGGING! Ground Screw Foundation System Design Declaration.
- A current copy of the STOPDIGGING! Installation Guide.

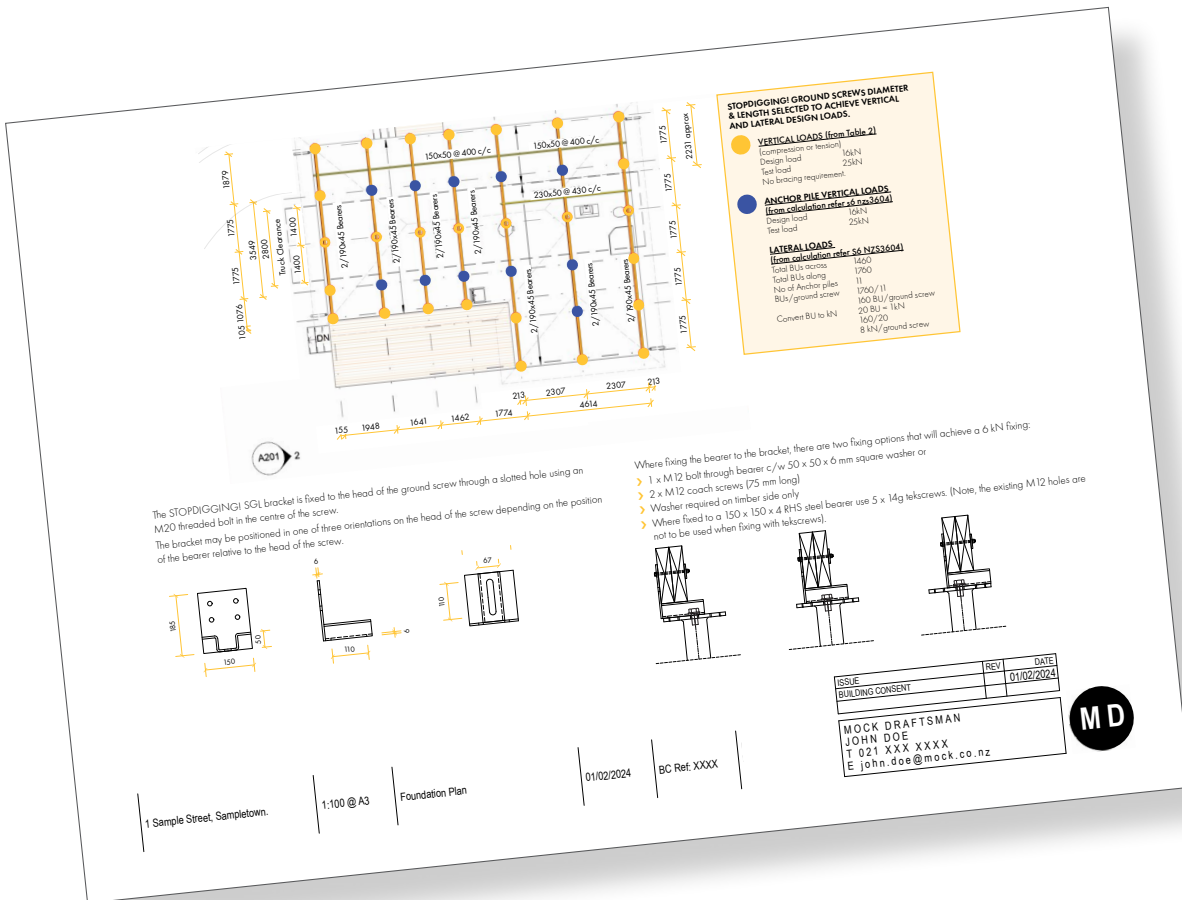

## **PART 2** FOR BUILDING PROJECTS REQUIRING SPECIFIC ENGINEERING FOUNDATION DESIGN

### **INTRODUCTION**

#### **SCOPE**

Part 2 applies to projects where **Part 1** does not apply. This part is referred to as 1 (b) in the **CodeMark Certificate of Conformity**.

Projects include:

- › Ground screws supporting concrete slabs on grade when piles are needed to transfer loads to a depth below the existing subgrade level. Using ground screws removes the need for a cantilever slab design or thickened perimeter edge footings and acts as a method for improving the ground.
- › Where a geotechnical assessment has identified liquefiable potential classed as TC2 or TC3.
- › Where a geotechnical report has identified a minimum embedment depth is required to resist the potential for creep or lateral ground movement.
- › Where building work is proposed close to or over underground services/pipes or retaining walls, and the ground screw is required to transfer loads below the line of influence.
- › Where shear keys are required under a concrete slab or footing, and the ground screws are required to act as free head piles to resist lateral loads.
- › For cantilever piles where the bearer or joist spans are outside of the table in **Appendix 2** or where the ground screw head is > 900mm above ground level.

#### **SKILLS REQUIRED**

This part is intended for use by a CPEng engineer. It is expected that the engineer will complete the STOPDIGGING! Design Declaration in respect to the design work.

#### **IMPORTANT DOCUMENTS**

When using Part 2, the following documents will be required when lodging an application for building consent:

- › CodeMark Certificate of Conformity.
- › STOPDIGGING! Installation Guide.
- › STOPDIGGING! Design Declaration signed by the CPEng who designed or supervised the design on the foundation system.
- › Foundation plan and specification.
- › Engineering calculations.

Refer to [www.stopdigging.co.nz](http://www.stopdigging.co.nz) for current versions of STOPDIGGING! documents.

#### **WORKED EXAMPLES FOR PART 2**

Refer to **Appendix 4** for worked examples.



### DESIGN PROCESS



#### STEP 1 Confirm building scope

Confirm that the project is not within the scope of [Part 1](#).

Specification of the STOPDIGGING! Ground Screw foundation system may rely on the pre-engineered solution (refer part 1) or may be specifically designed as outlined in this part.

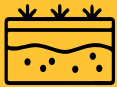

#### STEP 2 Confirm ground conditions

##### Confirm ground conditions

Check the soil suitability. [Table 2](#), Appendix 1 provides a soil suitability matrix.

Confirm that the site-specific soil type is listed as suitable.

Where the soil is not covered in Table 2, site soil testing and a geotechnical report will be required as part of the design process.

##### Confirm ground stability

Refer to council files and the applicable GIS to determine if liquefaction or other ground stability must be factored in when specifying the foundation system.

Where a geotechnical report is required, the geotechnical engineer may design the foundation system, if this falls within their scope. Alternatively, a structural engineer may design the foundation system but is not bound by the geotechnical engineer's foundation recommendations of type or monitoring. The CodeMark Certificate of Conformity takes precedence over the geotechnical report.



#### STEP 3 Determine Design Loads & Ground Screw Position

##### Specify lateral and compression or tension loads

The STOPDIGGING! ground screw foundation system must be specified with reference to the ULS design loads assigned to each ground screw.

Design loads should be calculated in ULS, with a suitable geotechnical safety factor between 0.6 and 0.8 depending on application.

When used in conjunction with a subfloor, the ground screws can act as a cantilever "free head" pile whether bracing units are evenly or unevenly distributed.

### Note: On-site testing

The static pile test that must be undertaken prior to the installation of the foundation system must demonstrate that capacity is achieved to 100 % of the specified test load (compressive or tension and lateral) as well as additional requirements, including embedment depth, where this is required due to site-specific geotechnical features.

### Specify ground screw position

The location of the ground screws should denote perimeter ground screw positions and locations under point loads as applicable. Individual ground screw design and test loads must be clearly marked on the plan.

Where a geotechnical or other site feature applies, this should be referenced clearly on the plan.

Ground screws may be used for bridging buried services and slab edges close to retaining walls, allowing load to be transferred below the zone of influence.

### Under slab support

Ground screws may be used to support concrete slabs on grade when piles are needed to transfer loads to a depth below the existing subgrade level. The use of ground screws removes the need for a cantilever slab design or thickened perimeter edge footings and acts as a method for improving the ground.

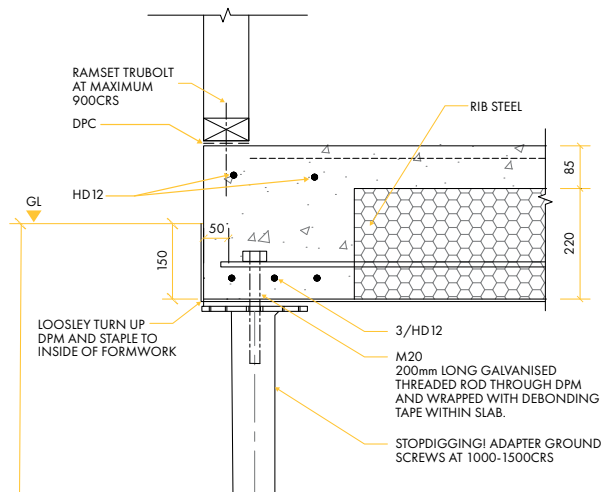

▲ FIGURE 4. GROUND SCREW SUPPORTING CONCRETE SLAB



## STEP 4 Specify diagonal bracing

If diagonal bracing is required, two options are available: a timber senton pile or steel pipe diagonal bracing used in conjunction with the ground screw. The foundation plan must show the lateral design loads and position/direction of the bracing element.

**Timber senton pile**

A timber senton pile is fixed to the top of a ground screw with the SGE bracket. The timber diagonal bracing unit is then fixed to the senton posts, as per NZS 3604:2011, section 6.88.

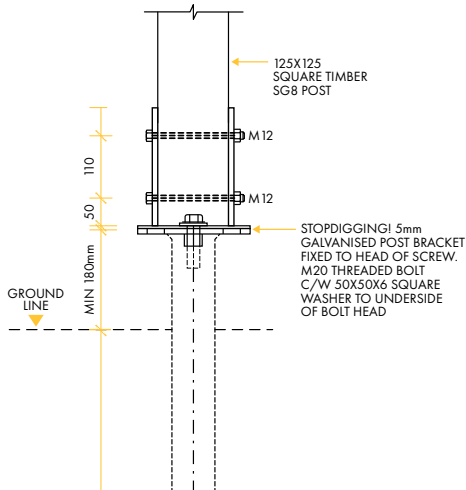

▲ FIGURE 3. BRACKET SGL125 FIXED TO THE SENTON PILE

**Diagonal Steel Pipe**

A steel pipe diagonal bracing unit may be specified as follows.

- 48.3 CHS Grade 250 tube. In exposure zone D, the tube must have a min 125 µm zinc cover or other coating.
- A maximum length of 3.2 m.
- At an angle between 10° and 45° from horizontal.
- The bracing unit is to be connected with a clamp type swivel coupler that has an established capacity of greater than 6 kN.
- The bracing unit must be fixed at least 100 mm above ground level.

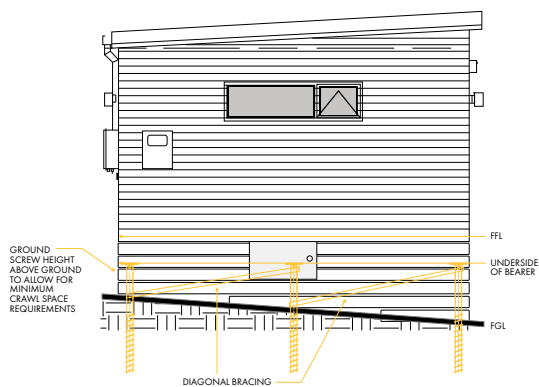

▲ FIGURE 5. DIAGONAL BRACING

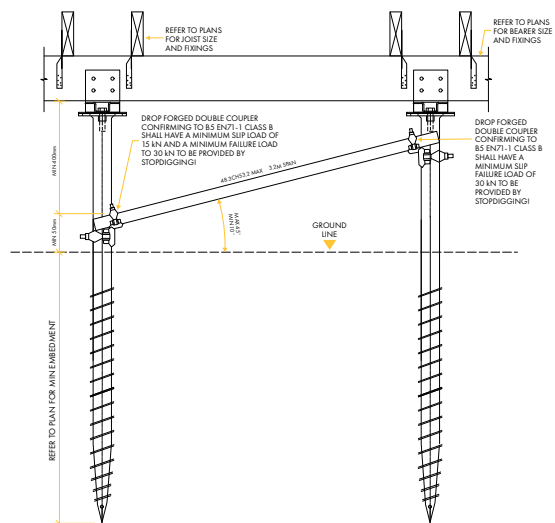

▲ STEEL PIPE DIAGONAL BRACE DETAIL



**STEP 5**

**Specify ground screws, connections & fixings**

**Select ground screw**

Specify SGC or SGU ground screws. Size (diameter and length) are confirmed at the time of static pile testing. However, the following should be specified:

- SGU Screws are required for decks where the fall height is < 1 m.
- SGC Screws are required for all other uses.

Where additional durability for marine environments (e.g., immersion in seawater) is required, then the SGC ground screw range is available with an increased wall thickness and a DUP factory-applied epoxy coating.

**Specify connections**

Where appropriate, the STOPDIGGING! SGL Bracket should be used for fixing bearer to pile. The bracket is fixed to the head of the ground screw through a slotted hole using an M20 threaded bolt in the centre of the screw.

The bracket may be positioned in one of three orientations on the head of the screw, depending on the position of the bearer relative to the head of the screw.

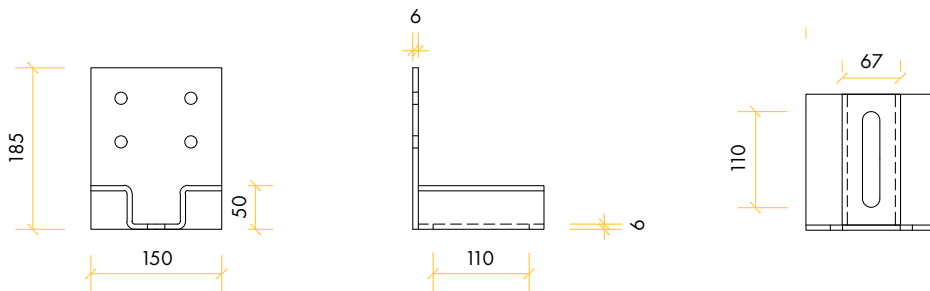

▲ FIGURE 1. BRACKET SGL145

**Specify fixings**

Where fixing the bearer to the bracket, there are two fixing options that will achieve a 6 kN fixing:

- 1 x M12 bolt through bearer c/w, or
- 2 x M12 coach screws (75 mm long).
- Washer required on timber side only
- Where fixed to a 150X50X4 RHS steel bearer use 5 x 14g tek screws. (Note, the existing M12 holes are not to be used when fixing with tek screws.)

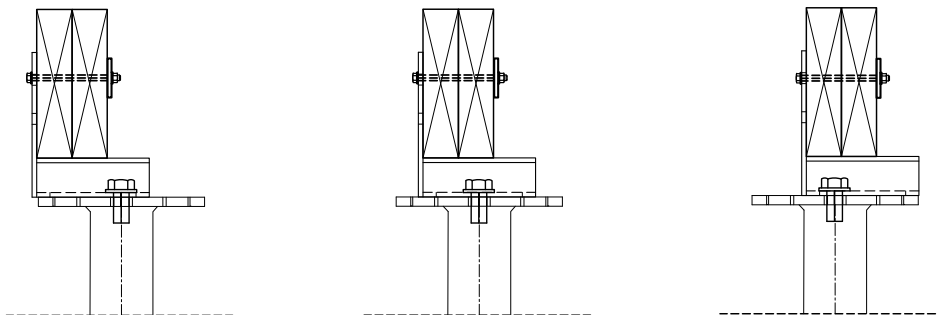

▲ FIGURE 2. POSITION OF GROUND SCREW

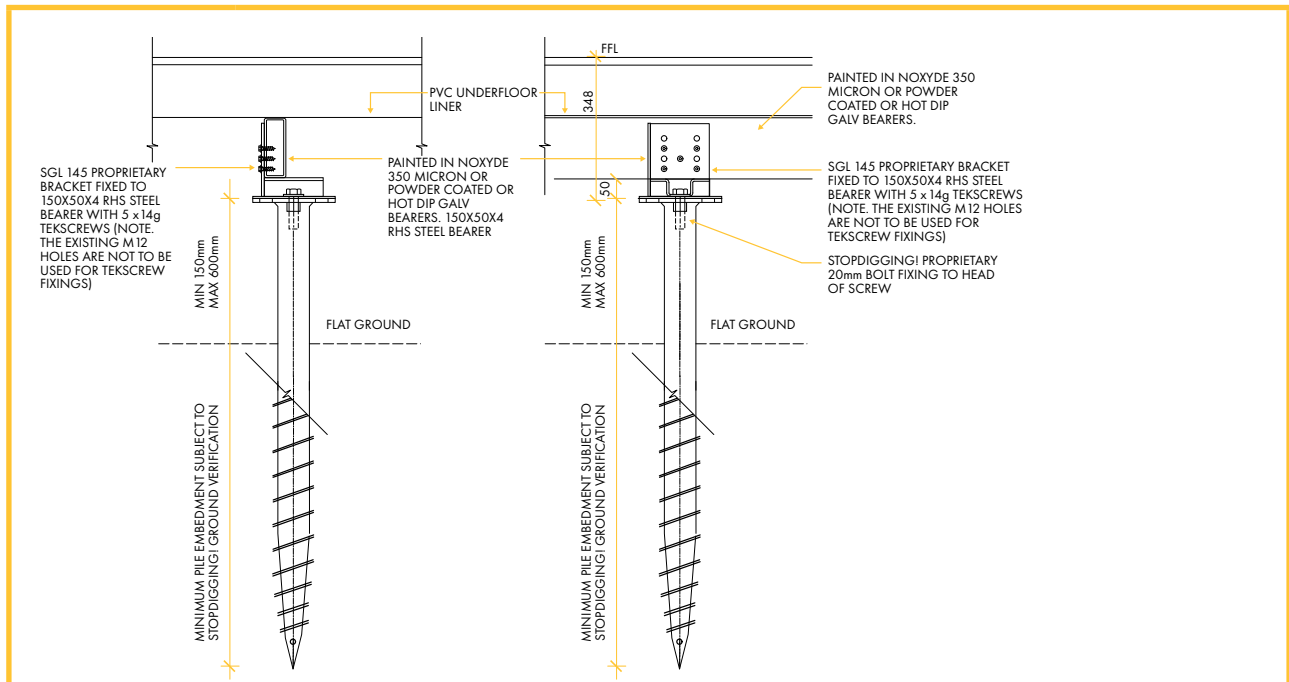

▲ FIGURE 6. SGC ADAPTOR SCREW PILE SGL 145 STOPDIGGING! BRACKET

Where the SGL bracket is not suitable, the following steps should be carried out to calculate fixing requirements.

- Select project values using the following table:

**TABLE 1: SECTION CAPACITIES**

	New (Complete Section)				50-year Design Life (0.5 mm reduced wall thickness)				100-year Design Life (1 mm reduced wall thickness)			
	600	1200	600	1200	600	1200	600	1200				
Installed Height Above Ground (mm)	600	1200	600	1200	600	1200	600	1200				
CHS Section Size	N <sub>s</sub>	M <sub>s</sub>	N <sub>c</sub>	M <sub>n</sub>	N <sub>c</sub>	M <sub>n</sub>	N <sub>c</sub>	M <sub>n</sub>	N <sub>c</sub>	M <sub>n</sub>	N <sub>c</sub>	M <sub>n</sub>
114 x 4	323.2	8.6	311.8	8.6	284.1	7.7	274.1	7.7	244.6	6.6	236.0	6.6
89x5	308.5	6.2	297.7	6.2	279.3	5.6	269.5	5.6	249.8	5.1	241.0	5.1
89x4	249.8	5.1	241.0	5.1	220.0	4.5	212.3	4.5	189.7	4.0	183.0	4.0
76x4	210.5	3.6	200.7	3.6	185.5	3.2	177.0	3.2	160.2	2.8	152.8	2.8
67x3	139.6	2.2	131.5	2.2	117.4	1.9	110.6	1.9	94.6	1.5	89.3	1.5
67x2	94.6	1.5	89.3	1.5	71.5	1.2	67.5	1.2	48.1	0.8	45.4	0.8

### > Abbreviations

- $N_s$  = nominal section capacity of compression member (kN)
- $M_s$  = nominal section moment capacity (kNm)
- $N_c$  = nominal member capacity in compression (kN)
- $M_n$  = nominal member moment capacity (kNm)

### > Calculate for combined action.

### > Calculate for bearer connection using STOPDIGGING! brackets. The following steps are required:

- Specify the connection from the bearer to the bracket.
- Consider the bending capacity of the steel bracket.
- Design the weld strength between the plates.
- Specify steel bolt in slotted hole - bracket to ground screw connection.
- Calculate bearing length of bearer on to bracket.

Refer to [Appendix 4](#) for example engineering calculations for fixing requirements.

The STOPDIGGING! Ground Screw foundation system must be specified with reference to the loads applicable to each ground screw. While the type of ground screw should be identified, the diameter and length are determined during the on-site static pile testing.

The static pile test, a prerequisite before implementing the foundation system installation, should demonstrate that the specified test load capacities (both lateral and compressive/tension) have been achieved as required by the engineer. This encompasses meeting additional requirements, including embedment depth, where this is required due to site-specific geotechnical features.

Where additional height is required, adapter screws are used in conjunction with SGC EL extension pipes and SGL brackets.

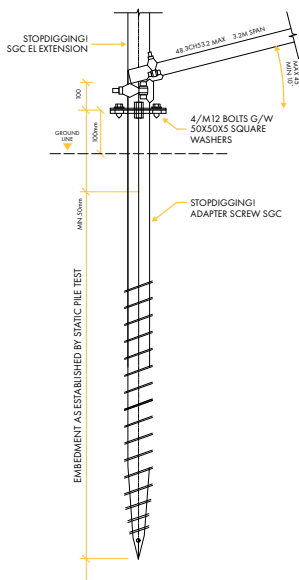

▲ FIGURE 7. BRACED SCREWS WITH SGC EL EXTENSION



#### STEP 6

#### Complete building consent documentation

To ensure consenting is streamlined, check that the following is provided:

- › A single plan page showing foundation design and clearly detailing,
  - the position of the ground screws
  - the type of ground screw, but not the dimension or length
  - the brackets
  - connection details
  - fixing details
  - lateral design and test loads
  - compressive or tension design and test loads.
- › Engineering calculations/design report.
- › Current copy of the STOPDIGGING! Ground Screw Foundation System CodeMark.
- › STOPDIGGING! Ground Screw Foundation System Design Declaration signed by the CPEng who designed or supervised the design of the foundation system.
- › Current copy of the STOPDIGGING! Installation Guide.

**APPENDIX 1 – SOIL SUITABILITY**

**TABLE 2: SUITABILITY OF GROUND SCREWS BASED ON SOIL TYPE**

MAJOR SOIL TYPE	SUITABILITY <sup>1</sup>	RATIONALE
Silt	Yes	Silt can generally be predrilled with a suitable soil auger, allowing for installation of the ground screws.
Sand	Yes	Ground screws can generally displace sands during installation.
Fine gravel	Yes	Fine gravels are expected to behave in a similar way to sands.
Medium gravel	Requires on-site confirmation	Medium gravels may become disturbed during installation, diminishing the bond strength between the ground screw and the soil. As such the suitability of the soils will need to be confirmed with on-site testing.
Coarse gravel	Requires on-site confirmation	Coarse gravels may become disturbed during installation, diminishing the bond strength between the ground screw and the soil. As such the suitability of the soils will need to be confirmed with on-site testing.
Cobbles	No	Cobbles are expected to become disturbed during installation or prevent installation altogether due to penetration resistance. Disturbed cobbles would have a greatly diminished bond strength to the installed ground screw.
Boulders	No	It is unlikely that the predrilling process or the ground screw installation will be able to penetrate through soil medium comprising boulders as the main constituent.
Clay	Yes	Clays can generally be augured, allowing the predrilling process to be completed successfully and in most cases shall allow for the successful installation of the ground screws.
Peat	No	Peat is an organically dominated material that is unsuitable for most shallow foundation types.
Topsoil	No	Topsoil is an organically dominated material that is unsuitable for most shallow foundation types.
Rock	No	Predrilling is generally unsuccessful into bedrock and ground screws are unable to displace rock during installation.
Non-engineered fill	No	Non-engineered fills are inconsistent material with unpredictable characteristics. Uncontrolled fill lacks the horizontal stratification that is common in naturally deposited materials. As such, localised soil and load testing cannot be used to infer the performance or the load carrying characteristics of the soil across an entire site.

<sup>1</sup> Assuming soil is sufficiently dense



**APPENDIX 2 – DESIGN AND TEST LOADS**

**TABLE 3: 1.5 kPa AND 2 kPa FLOOR LOADS**

SPAN* OF		DESIGN & TEST LOADS FOR GROUND SCREWS							
Bearer (m)	Joists (m)	Floor and non-loadbearing walls only		1 storey		2 storey		3 storey	
		Design Load	Test Load	Design Load	Test Load	Design Load	Test Load	Design Load	Test Load
1.30	2.0	6kN	10kN	11kN	20kN	16kN	25kN	18kN	30kN
	3.5	8kN	15kN	18kN	30kN	27kN	40kN	34kN	50kN
	5.0	11kN	20kN	27kN	40kN	40kN	60kN <sup>†</sup>	45kN	70kN <sup>†</sup>
	6.0	14kN	25kN	30kN	45kN	45kN	70kN <sup>†</sup>	55kN	85kN <sup>†</sup>
1.65	2.0	6kN	10kN	14kN	25kN	21kN	35kN	24kN	40kN
	3.5	9kN	15kN	27kN	40kN	33kN	50kN	40kN	60kN <sup>†</sup>
	5.0	14kN	25kN	30kN	45kN	50kN	75kN <sup>†</sup>	55kN	85kN <sup>†</sup>
2.00	2.0	6kN	10kN	16kN	25kN	27kN	40kN	30kN	45kN
	3.5	11kN	20kN	27kN	40kN	41kN	60kN	55kN	85kN <sup>†</sup>

\*Span is the average of the bearer or joist spans on either side of the pile under consideration

<sup>†</sup>Special consideration is required for these loads, please contact Stopdigging, for technical advice.

**TABLE 4: 3 kPa FLOOR LOADS**

MAXIMUM SPANS* OF		DESIGN & TEST LOADS FOR GROUND SCREWS					
Bearers (m)	Joists (m)	Floor only		Floor and walls of:			
		Design Load	Test Load	1 storey		2 storeys	
		Design Load	Test Load	Design Load	Test Load	Design Load	Test Load
1.30	2.0	8kN	15kN	14kN	25kN	21kN	35kN
	3.5	14kN	25kN	24kN	40kN	38kN	60kN <sup>†</sup>
	5.0	16kN	25kN	30kN	45kN	50kN	75kN <sup>†</sup>
	6.0	18kN	30kN	38kN	60kN <sup>†</sup>	59kN	90kN <sup>†</sup>
1.65	2.0	9kN	15kN	18kN	30kN	27kN	40kN
	3.5	16kN	25kN	27kN	40kN	50kN	75kN <sup>†</sup>
	5.0	21kN	35kN	38kN	60kN <sup>†</sup>	63kN	95kN <sup>†</sup>
2.00	2.0	11kN	20kN	21kN	35kN	34kN	50kN
	3.5	21kN	35kN	34kN	50kN	59kN	90kN <sup>†</sup>

\*Span is the average of the bearer or joist spans on either side of the pile under consideration.

<sup>†</sup>Special consideration is required for these loads, please contact Stopdigging, for technical advice.

Note: the above tables relied on the following assumptions

ULS bearing capacity = 150 kPa

ULS vertical capacity of pad = 150 kPa x 0.275m x 0.275 m = 11 kN

**APPENDIX 3 – FOUNDATION SYSTEM WORKED EXAMPLES**

The following worked examples are provided for the following scenarios that relate to Part 1:

- Example 1: Level site with cantilevered piles
- Example 2: Level site with Anchor and ordinary piles
- Example 3: Sloping ground with cantilevered piles.

**FOUNDATION SYSTEM WORKED EXAMPLES**

**Example 1: Level site with cantilevered piles**

All ground screw foundations are to act as cantilevered piles with the total subfloor bracing demand being shared by all screws.

All ground screws must have connections to the bearer that are suitable to transfer the required lateral load per screw. The STOPDIGGING! SGL 145 bracket should be used.

On-site testing is completed at the maximum height that the ground screws are installed to provide accurate ultimate load capacities.

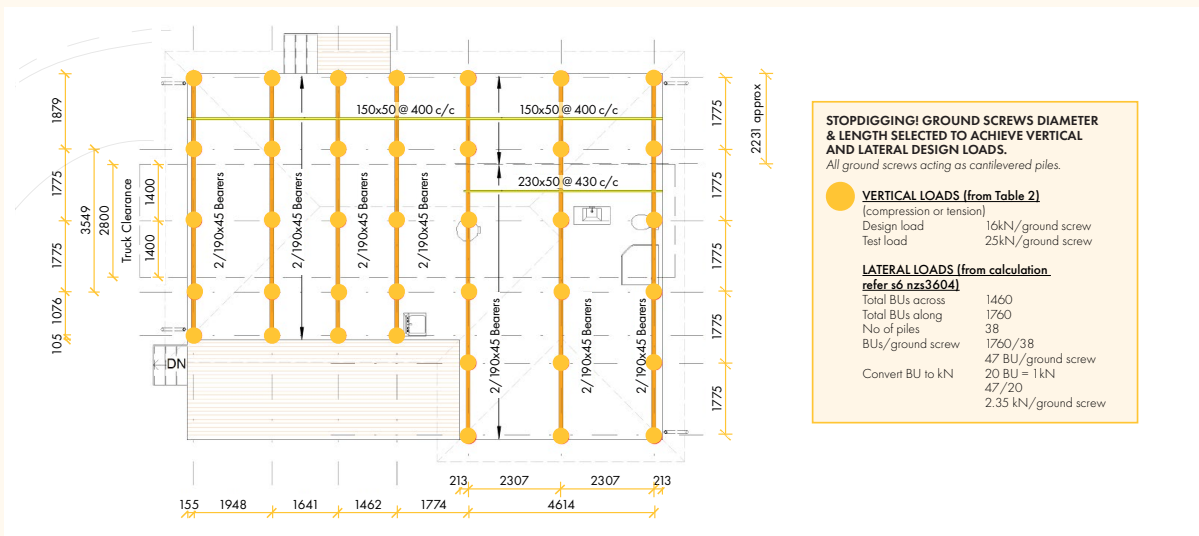

▲ EXAMPLE 1. LEVEL SITE WITH CANTILEVERED PILES

### Example 2: Level site with anchor and ordinary pile

Anchor piles (anchor screws) are nominated on subfloor bracing lines to resist the subfloor bracing demand. Anchor screws must have connections to the bearer that are suitable to transfer the required lateral load per anchor pile. The STOPDIGGING! SGL 145 bracket should be used.

Ordinary piles are required to support vertical loads only. For simplicity the STOPDIGGING! SGL 145 bracket should be used.

On-site testing is completed at the maximum height that the ground screws are installed to provide accurate ultimate load capacities.

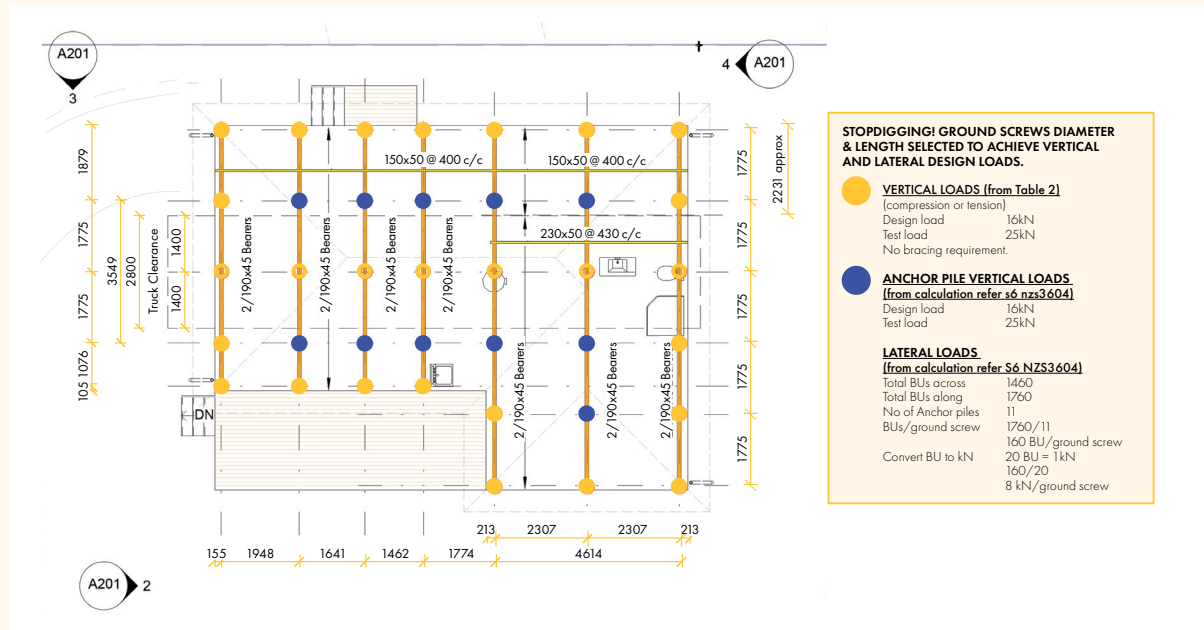

▲ EXAMPLE 2. LEVEL SITE WITH ANCHOR AND ORDINARY PILE

### Example 3: Sloping ground with cantilevered piles

All ground screw foundations to act as cantilevered piles so that the total subfloor bracing demand can be shared by all piles.

All ground screws must have connections to the bearer that are suitable to transfer the required lateral load per screw. The STOPDIGGING! SGL 145 bracket should be used.

On-site testing is completed at the maximum height that the ground screws are installed to provide accurate ultimate load capacities.

Larger diameter and longer screws can be used to provide additional stiffness and embedment depth where needed to provide lateral capacity to screws with greater clearances to the underside of the bearer.

Where additional height is required, adapter screws are used in conjunction with SGC EL extension pipes and SGL brackets.

Note additional testing must be completed by STOPDIGGING! for each length/size of screw.

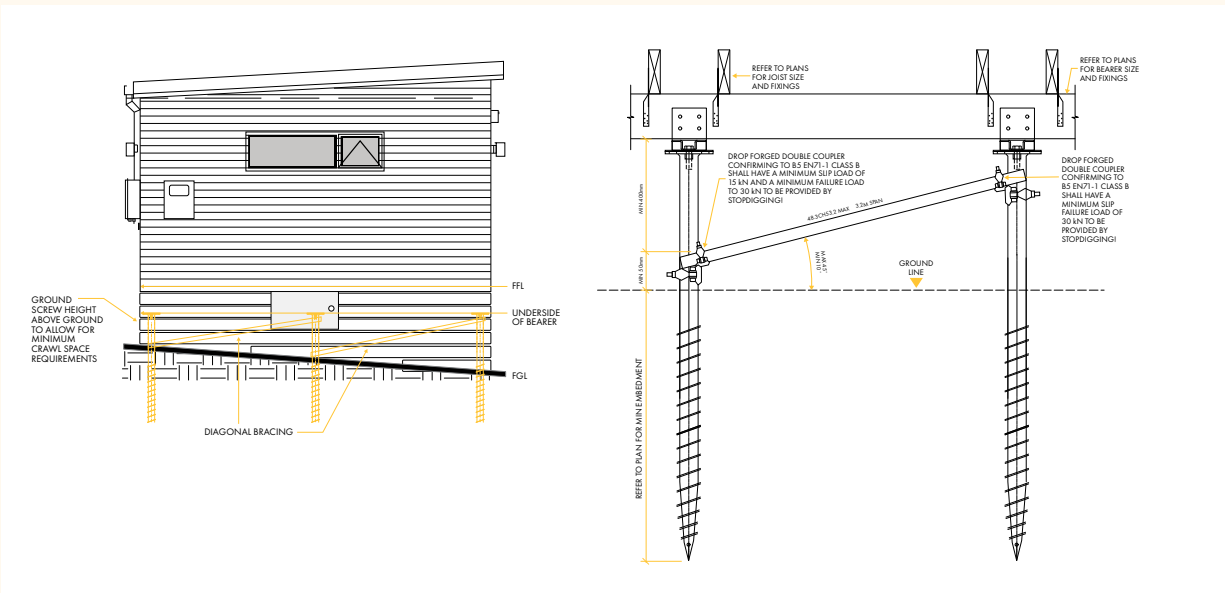

▲ FIGURE 5. DIAGONAL BRACING

▲ STEEL PIPE DIAGONAL BRACE DETAIL



▲ FIGURE 7. BRACED SCREWS WITH SGC EL EXTENSION

**APPENDIX 4 – EXAMPLE ENGINEERING CALCULATIONS**

The following examples show how to apply engineering calculations in conjunction with the STOPDIGGING! brackets and ground screws.

All abbreviations have the meaning provided in steel and timber engineering standards and are given the normally accepted meaning.

**EXAMPLE CALCULATIONS FOR FIXING REQUIREMENTS**

**Calculate for combined action**

Assume project values as follows using Table 1 Section capacities (refer to Part 2):

Section:	76 x 4 Ground Screw
Height above Ground:	600 mm
Assumed Design Life:	100 years
Vertical Load (ULS)	N = 20 kN
Lateral Load (ULS)	V = 3 kN

Calculations are as follows

$$\begin{aligned}
 M^* &= 0.6 \text{ m} \times 3 \text{ kN} &= 1.8 \text{ kNm} \\
 \Phi M_n &= 0.9 \times 2.8 \text{ kNm} &= 2.5 \text{ kNm} \\
 \Phi N_c &= 0.9 \times 160.2 \text{ kN} &= 144.2 \text{ kN} \\
 \Phi M_r &= \Phi M_b \times (1 - (N^* / \Phi N)) \\
 &= 2.5 \text{ kNm} \times (1 - (20 / 137.5)) &= 2.1 \text{ kNm} > M^*
 \end{aligned}$$

**Calculate for bearer connection**

Use STOPDIGGING! SGL 145 designed to transfer lateral load of 3 kN from the bearer to the ground screw head. SGL 145 Bracket should be used for fixing bearer to pile. The bracket is fixed through a slotted hole using an M20 threaded bolt in the centre of the screw.

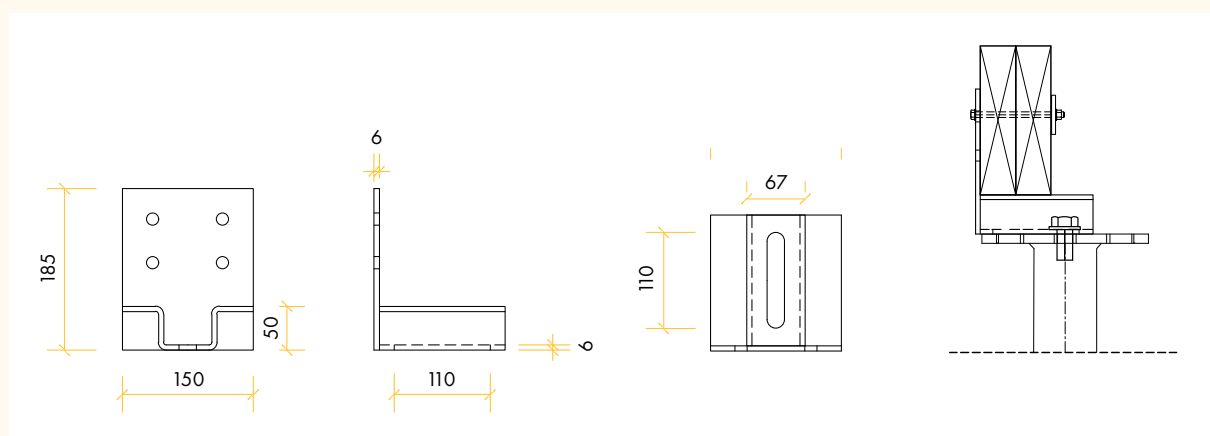

▲ FIGURE 1. BRACKET SGL145

### 1. Specify connection from bracket to bearer

#### Option A: 1 x M12 bolt

Bolt acting in tension (loaded at 90° to bearer)

$$N^*t = 3 \text{ kN}$$

Tensile capacity of M12 bolt confirmed by inspection  
( $\Phi N_t = 27.0 \text{ kN}$ )

Connection is governed by the bearing strength of the washer.

Propose 50 mm x 50 mm x 6 mm square washers.

$$A_p = (50 \text{ mm})^2 - \pi \times (14 \text{ mm})^2 / 4$$

$$= 2356 \text{ mm}^2$$

$$\Phi N_{nb} = \Phi \times k_1 \times k_3 \times f_p \times A_p$$

$$= 0.7 \times 1.0 \times 1.0 \times 8.9 \text{ MPa} \times 2356 \text{ mm}^2 / 1000$$

$$= 14.7 \text{ kN}$$

$$= > 0.3 \text{ kN}$$

Bolt acting in shear (loaded at 0° to bearer)

Loading parallel to grain

$$B_e = 90 \text{ mm}$$

$$Q_{skl} = 10.4 \text{ kN} \times 1.25$$

$$= 13.0 \text{ kN}$$

(Alternative steel & timber members)

$$\Phi Q_n = \Phi \times n \times k_1 \times k_{12} \times k_{13} \times Q_{sk}$$

$$= 0.7 \times 1.0 \times 1.0 \times 1.0 \times 1.0 \times 13.0$$

$$= 9.1 \text{ kN}$$

$$> 3 \text{ kN}$$

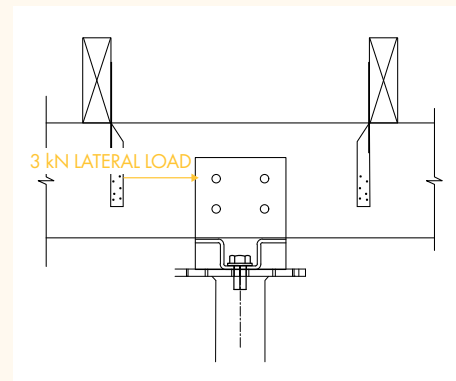
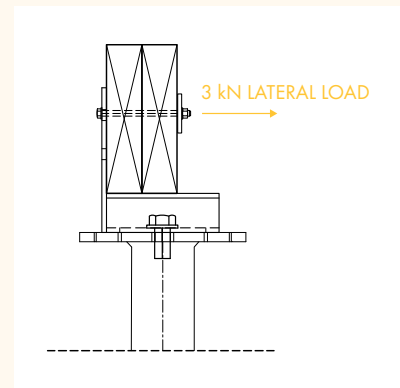

#### Option B 2 x M12 75 mm coach screws

Coach screws acting in tension (loaded at 90° to bearer)

$$N^*t = 3 \text{ kN}$$

Tensile capacity of M12 coach screw confirmed by inspection. Connection is governed by the withdrawal strength of the coach screw.

Propose 2 mm x 75 mm M12 coach screws.

$$\text{Coach screw embedment} = 75 \text{ mm} - (6 \text{ mm} + 5 \text{ mm}) = 64 \text{ mm}$$

$$\Phi Q_n = \Phi \times n \times k_1 \times p \times Q_k$$

$$= 0.7 \times 2.0 \times 1.0 \times 64 \text{ mm} \times 118 \text{ N/mm} / 1000 = 10.6 \text{ kN}$$

$$> 3 \text{ kN}$$

Coach screws acting in shear (loaded at 0° to bearer)

Loading parallel to grain

$$\begin{aligned}
 B_e &= 90 \text{ mm} \\
 Q_{skl} &= 10.4 \text{ kN} \times 1.25 = 13.0 \text{ kN} \\
 &\text{(Alternative steel \& timber members)} \\
 \Phi Q_n &= \Phi \times n \times k_1 \times k_{12} \times k_{13} \times k \times Q_{sk} \\
 &= 0.7 \times 2.0 \times 1.0 \times 1.0 \times 1.0 \times 0.5 \times 13.0 \\
 &= 9.1 \text{ kN} \\
 &> 3 \text{ kN}
 \end{aligned}$$

**2. Consider bending capacity of steel bracket**

Steel yield

Stress  $f_y = 250 \text{ MPa}$

Plate thickness,  $t = 6 \text{ mm}$

Plate bending strength at section A:

$$\begin{aligned}
 \Phi M_n &= \Phi \times f_y \times Z \\
 Z &= b \times d^2 / 4 \\
 &= 150 \times 62^2 / 4 = 1350 \text{ mm}^3 \\
 \Phi M_n &= \Phi \times f_y \times Z \\
 &= 0.9 \times 250 \text{ MPa} \times 1350 \text{ mm}^3 \times 10^{-6} \\
 &= 0.30 \text{ kNm}
 \end{aligned}$$

Propose M12 bolt in top hole (worst case<sup>2</sup>)

$$\begin{aligned}
 M^* &= 3 \text{ kN} \times 0.1 \text{ m} \\
 &= 0.30 \text{ kN therefore OK.}
 \end{aligned}$$

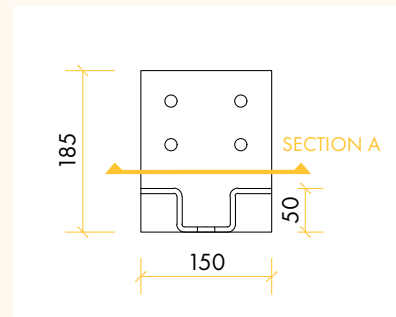
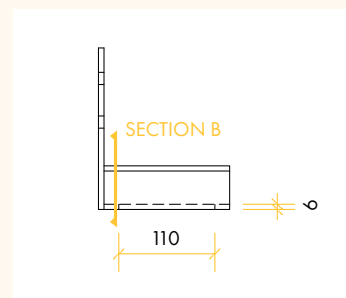

Plate bending strength at section B:

Calculate section properties of irregular section:

PART	A (mm <sup>2</sup> )	I (mm <sup>4</sup> )	y (mm)	I <sub>y</sub>	d (mm)	Ad <sup>2</sup>
1	228	684	3	2052	22	110352
2	192	16384	25	409600	0	0
3	90	270	47	12690	22	43560
<b>TOTAL:</b>	<b>34676</b>	<b>848684</b>				

$$\begin{aligned}
 y' &= 848684 / 34676 \\
 &= 25 \text{ mm} \\
 I_{\text{section}} &= I + Ad^2 \\
 &= 342500 \text{ mm}^4 \\
 Z_{\text{section}} &= I / y' \\
 &= 13700 \text{ mm}^3
 \end{aligned}$$



<sup>2</sup> M12 bolt to bottom hole would reduce lever arm

Check slenderness of flanges

$$\begin{aligned}
 b &= 38 \text{ mm} \\
 t &= 6 \text{ mm} \\
 \lambda_e &= 6.3 \\
 \lambda_{ep} &= 10 \\
 &= \lambda_{sp} \\
 \lambda_{ey} &= 16 \\
 &= \lambda_{sy} \\
 \lambda_s &< \lambda_{sy} \text{ therefore, section is compact} \\
 Z_e &= 1.5 \times Z \\
 &= 20550 \text{ mm}^3 \\
 M_s &= 0.9 \times 250 \text{ MPa} \times 20550 \text{ mm}^3 \times 10^{-6} \\
 &= 4.6 \text{ kNm}
 \end{aligned}$$

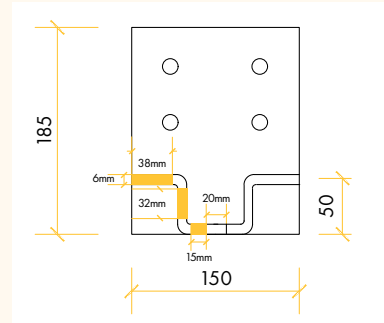

### 3. Design weld strength between plates

Propose 3 mm fillet weld SP 41 as a minimum, both sides of plates.

$$\begin{aligned}
 \text{Minimum weld length available} &= 30 \text{ mm} \\
 \text{Minimum weld strength} &= 2 \times 0.417 \text{ kN/mm} \times 30 \text{ mm} \\
 &= 25.0 \text{ kN} \\
 N_i^* = 0.3 \text{ kNm}/0.05 \text{ m} &= 6.0 \text{ kN} \\
 &< 25.0 \text{ kN therefore OK.}
 \end{aligned}$$

### 4. Specify steel bolt in slotted hole - bracket to ground screw connection

As per NZS 3404 section 9.3.3.1

Where slip in the SLS case is required to be limited, a bolt subjected only to a design shear force in the plane of the interfaces shall satisfy:

$$\begin{aligned}
 V_{sf}^* &\leq \Phi V_{sf} \\
 \Phi V_{sf} &= \Phi \times \mu_s \times n_{ei} \times N_{ti} \times k_h \\
 \mu_s &= 0.18 \text{ for galvanised surfaces} \\
 N_{ti} &= 145 \text{ kN for M20 (g8.8) bolts}
 \end{aligned}$$

Propose 50 mm x 50 mm x 6 mm square washer

$$\begin{aligned}
 \text{AREA, } A &= (502 - 50 \times 22) \text{ mm}^2 \\
 &= 1400 \text{ mm}^2 \\
 \Phi V_{sf} &= 0.7 \times 0.18 \times 2 \times 1400 \text{ mm}^2 \times 145 \text{ kN} \times 0.7 \times 10^{-3} \\
 &= 35.8 \text{ kN}
 \end{aligned}$$

Note: this is an SLS load case; therefore, the shear demand on the bolt will be less than 3 kN.



**5. Bearing length of bearer on to bracket**

$$\text{Minimum bearing length} = 38 \text{ mm}$$

$$\text{Distance from end of bearer} = 25 \text{ mm}$$

Minimum 90 mm wide bearer

$$\begin{aligned} \text{Bearing area, } A &= 90 \text{ mm} \times 38 \text{ mm} \\ &= 3420 \text{ mm}^2 \end{aligned}$$

For SG8 timber bearer:

$$\begin{aligned} \Phi N_b &= \Phi \times k_1 \times k_3 \times f_p \times A \\ &= 2 \times 0.8 \times 0.6 \times 1.0 \times 5.0 \text{ MPa} \times 3420 \text{ mm}^2 \times 10^{-3} \\ &= 16.4 \text{ kN} \end{aligned}$$

**Calculate section capacities**

Where Table 1 is not relied upon the following is an example calculation for section capacity using NZS3404 clause 6.2.

Example Calculation for section capacity – NZS 3404 clause 6.2

Section: 76 x 4

$$\begin{aligned} A_n &= A_g \\ &= (762 - 682) \times /4 \\ &= 905 \text{ mm}^2 \end{aligned}$$

$$k_f = 1.0$$

$$f_y = 235 \text{ MPa}$$

$$\begin{aligned} N_s &= k_f \times A_n \times f_y \\ &= 212.6 \text{ kN} \end{aligned}$$

This document is uncontrolled in printed form.  
See [www.stopdigging.co.nz](http://www.stopdigging.co.nz) for current version.